



Make it Short!

MARKUS FLEISCHLI
SULZER CHEMTECH

To achieve high quality mixing over the shortest distance and by the simplest technical means including a small pressure drop – with a new type of static mixer, Sulzer Chemtech can satisfy the customer's requirements in an amazing manner.

▶ Static mixers are an efficient and reliable solution if two components have to be mixed homogeneously or brought into contact with one another in a continuous process. They are found in various designs to suit different applications. In this respect, it is important whether the flow in the mixer is laminar or turbulent. In the case of laminar flows, the components are distributed in thinner and thinner layers, whereas eddies are generated in the case of turbulent flows.

A traditional static mixer comprises a housing that is usually welded together from a pipe and two

flanges. This contains several mixing elements. If necessary, the housing is fitted with a port or socket through which an additive can be fed.

The New Concept

With its "Compact" model, Sulzer Chemtech – with more than 25 years experience in mixing technology at its disposal – has now brought a mixer onto the market that is quite different: it comprises a narrow ring (without flanges) that is clamped between two pipe flanges. A single mixing element, together with a dosing port for additives, is integrated within this

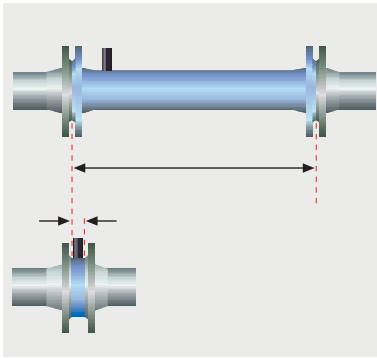

1 The installation length of the new «Compact» static mixer (below) from Sulzer Chemtech is significantly shorter than for conventional static mixers (top).

ring. The mixing element comprises three blades with specially shaped edges to break up the flow. The additive is fed behind the central blade. The mixer is designed for turbulent flow.

Simple, Economic Installation

The goal of the development was to reduce the installation length significantly compared with traditional mixers (Fig. 1), without incurring a greater pressure drop. Existing mixers have either a short insertion length and a high pressure drop, or a small pressure drop but with a longer installation length. Other goals were simple design, mounting, and cleaning. In addition, the purchase, installation, running, and maintenance costs, when taken together, were to be minimized.

A large number of experiments (Fig. 2) and CFD calculations (computational fluid dynamics; Fig. 3) confirmed that the goals were achieved:

- ▶ The installation length (the space required between the flanges) accounts for only 40% of the nominal pipe diameter.

- ▶ A result of this minimal space requirement is that the Compact can be inserted between two flanges of a pipe – an exceptionally simple and economic method of installation.
- ▶ Homogeneous mixing is already achieved three pipe diameters from the mixer. The mixing length is therefore significantly shorter compared with conventional static mixers.
- ▶ The mixing quality is independent of the mixing ratio.
- ▶ The pressure drop lies in the same range as conventional mixers, which is particularly remarkable given the short installation and mixing length.
- ▶ The mixer does not block and is easy to clean, thanks to its geometry.
- ▶ The price-performance ratio is attractive.

The Compact is available in six standard pipe diameters: 25, 40, 50, 80, 100, and 150 mm (other sizes available on request).

Flexible Manufacturing

Even in the manufacturing area, new paths were trodden. For the first time, a mixer (including ring) was milled from one solid block. This manufacturing method turned out to be particularly advantageous, at least for nominal pipe diameters up to 100 mm –



larger mixers will continue to be welded as before. In contrast to the casting method, there are practically no investment costs. Furthermore, the manufacturing method is very flexible with respect to the type of material and geometry.

In May 2003, Sulzer Chemtech introduced the new mixer at the Achema exhibition in Frankfurt am Main (Germany). There it stimulated a lot of interest and appeared to fulfill a real customer need. ◀

2 The additive (in the case a dye) is distributed over the entire cross-section even close to the dosing point. After three pipe diameters, the mixture is already homogeneous.

CONTACT

Sulzer Chemtech AG
 Marcel Suhner
 Postfach 65
 8404 Winterthur
 Switzerland
 Phone +41 (0)52-262 50 24
 Fax +41 (0)52-262 00 75
 marcel.suhner@sulzer.com

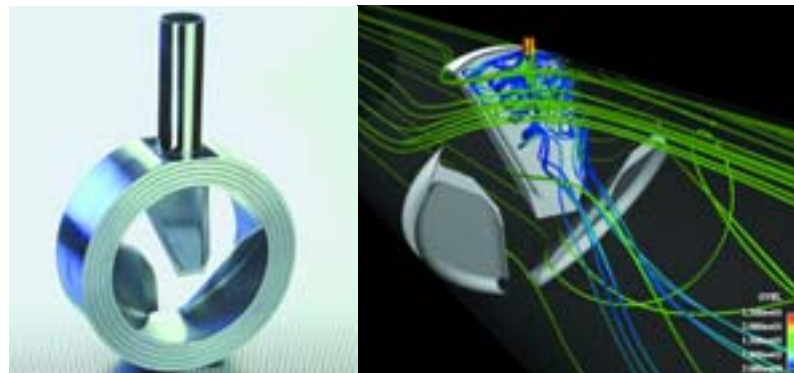

3 Numerical flow simulations by Sulzer Innotec reveal the intense turbulence of the additive that is fed from behind the central blade.